

01/2008:20214

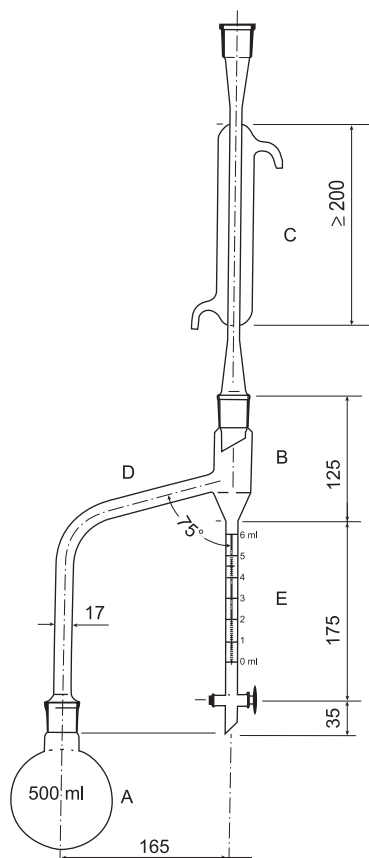

Figure 2.2.13-1. – Apparatus for the determination of water by distillation

Dimensions in millimetres

**Method.** Clean the receiving tube and the condenser of the apparatus, thoroughly rinse with water, and dry.

Introduce 200 ml of *toluene R* and about 2 ml of *water R* into the dry flask. Distil for 2 h, then allow to cool for about 30 min and read the water volume to the nearest 0.05 ml. Place in the flask a quantity of the substance, weighed with an accuracy of 1 per cent, expected to give about 2 ml to 3 ml of water. If the substance has a pasty consistency, weigh it in a boat of metal foil. Add a few pieces of porous material and heat the flask gently for 15 min. When the toluene begins to boil, distil at the rate of about two drops per second until most of the water has distilled over, then increase the rate of distillation to about four drops per second. When the water has all distilled over, rinse the inside of the condenser tube with *toluene R*. Continue the distillation for 5 min, remove the heat, allow the receiving tube to cool to room temperature and dislodge any droplets of water which adhere to the walls of the receiving tube. When the water and toluene have completely separated, read the volume of water and calculate the content present in the substance as millilitre per kilogram, using the formula:

$$\frac{1000 (n_2 - n_1)}{m}$$

- $m$  = the mass in grams of the substance to be examined,  
 $n_1$  = the number of millilitres of water obtained in the first distillation,  
 $n_2$  = the total number of millilitres of water obtained in the 2 distillations.

## 2.2.14. MELTING POINT - CAPILLARY METHOD

The melting point determined by the capillary method is the temperature at which the last solid particle of a compact column of a substance in a tube passes into the liquid phase. When prescribed in the monograph, the same apparatus and method are used for the determination of other factors, such as meniscus formation or melting range, that characterise the melting behaviour of a substance.

**Apparatus.** The apparatus consists of:

- a suitable glass vessel containing a liquid bath (for example, water, liquid paraffin or silicone oil) and fitted with a suitable means of heating,
- a suitable means of stirring, ensuring uniformity of temperature within the bath,
- a suitable thermometer with graduation at not more than 0.5 °C intervals and provided with an immersion mark. The range of the thermometer is not more than 100 °C,
- alkali-free hard-glass capillary tubes of internal diameter 0.9 mm to 1.1 mm with a wall 0.10 mm to 0.15 mm thick and sealed at one end.

**Method.** Unless otherwise prescribed, dry the finely powdered substance *in vacuo* and over *anhydrous silica gel R* for 24 h. Introduce a sufficient quantity into a capillary tube to give a compact column 4 mm to 6 mm in height. Raise the temperature of the bath to about 10 °C below the presumed melting point and then adjust the rate of heating to about 1 °C/min. When the temperature is 5 °C below the presumed melting point, correctly introduce the capillary tube into the instrument. For the apparatus described above, immerse the capillary tube so that the closed end is near the centre of the bulb of the thermometer, the immersion mark of which is at the level of the surface of the liquid. Record the temperature at which the last particle passes into the liquid phase.

**Calibration of the apparatus.** The apparatus may be calibrated using melting point reference substances such as those of the World Health Organisation or other appropriate substances.

01/2008:20215

## 2.2.15. MELTING POINT - OPEN CAPILLARY METHOD

For certain substances, the following method is used to determine the melting point (also referred to as slip point and rising melting point when determined by this method).

Use glass capillary tubes open at both ends, about 80 mm long, having an external diameter of 1.4 mm to 1.5 mm and an internal diameter of 1.0 mm to 1.2 mm.

Introduce into each of 5 capillary tubes a sufficient amount of the substance, previously treated as described, to form in each tube a column about 10 mm high and allow the tubes to stand for the appropriate time and at the prescribed temperature.

Unless otherwise prescribed, substances with a waxy consistency are carefully and completely melted on a water-bath before introduction into the capillary tubes. Allow the tubes to stand at 2-8 °C for 2 h.