

2.9. PHARMACEUTICAL TECHNICAL PROCEDURES

01/2008:20901

2.9.1. DISINTEGRATION OF TABLETS AND CAPSULES

This test is provided to determine whether tablets or capsules disintegrate within the prescribed time when placed in a liquid medium under the experimental conditions presented below.

For the purposes of this test, disintegration does not imply complete dissolution of the unit or even of its active constituent. Complete disintegration is defined as that state in which any residue of the unit, except fragments of insoluble coating or capsule shell, remaining on the screen of the test apparatus or adhering to the lower surface of the discs, if used, is a soft mass having no palpably firm core.

Use apparatus A for tablets and capsules that are not greater than 18 mm long. For larger tablets or capsules use apparatus B.

TEST A - TABLETS AND CAPSULES OF NORMAL SIZE

Apparatus. The apparatus consists of a basket-rack assembly, a 1 litre, low-form beaker, 149 ± 11 mm in height and having an inside diameter of 106 ± 9 mm for the immersion fluid, a thermostatic arrangement for heating the fluid between 35°C and 39°C , and a device for raising and lowering the basket in the immersion fluid at a constant frequency rate between 29 and 32 cycles per minute, through a distance of 55 ± 2 mm. The volume of the fluid in the vessel is such that at the highest point of the upward stroke the wire mesh remains at least 15 mm below the surface of the fluid, and descends to not less than 25 mm from the bottom of the vessel on the downward stroke. At no time should the top of the basket-rack assembly become submerged. The time required for the upward stroke is equal to the time required for the downward stroke, and the change in stroke direction is a smooth transition, rather than an abrupt reversal of motion. The basket-rack assembly moves vertically along its axis. There is no appreciable horizontal motion or movement of the axis from the vertical.

Basket-rack assembly. The basket-rack assembly consists of 6 open-ended transparent tubes, each 77.5 ± 2.5 mm long and having an inside diameter of 21.85 ± 1.15 mm and a wall 1.9 ± 0.9 mm thick; the tubes are held in a vertical position by 2 plates, each 90 ± 2 mm in diameter and 6.75 ± 1.75 mm in thickness, with 6 holes, each 24 ± 2 mm in diameter, equidistant from the centre of the plate and equally spaced from one another. Attached to the under surface of the lower plate is a woven stainless steel wire cloth, which has a plain square weave with 2.0 ± 0.2 mm mesh apertures and with a wire diameter of 0.615 ± 0.045 mm. The parts of the apparatus are assembled and rigidly held by means of 3 bolts passing through the 2 plates. A suitable means is provided to suspend the basket-rack assembly from the raising and lowering device using a point on its axis.

The design of the basket-rack assembly may be varied somewhat provided the specifications for the glass tubes and the screen mesh size are maintained. The basket-rack assembly conforms to the dimensions shown in Figure 2.9.1-1.

Discs. The use of discs is permitted only where specified or allowed. Each tube is provided with a cylindrical disc 9.5 ± 0.15 mm thick and 20.7 ± 0.15 mm in diameter. The

disc is made of a suitable, transparent plastic material having a specific gravity of 1.18-1.20. 5 parallel 2 ± 0.1 mm holes extend between the ends of the cylinder. One of the holes is centered on the cylindrical axis. The other holes are centered 6 ± 0.2 mm from the axis on imaginary lines perpendicular to the axis and parallel to each other. 4 identical trapezoidal-shaped planes are cut into the wall of the cylinder, nearly perpendicular to the ends of the cylinder. The trapezoidal shape is symmetrical; its parallel sides coincide with the ends of the cylinder and are parallel to an imaginary line connecting the centres of 2 adjacent holes 6 mm from the cylindrical axis. The parallel side of the trapezoid on the bottom of the cylinder has a length of 1.6 ± 0.1 mm and its bottom edges lie at a depth of 1.6 ± 0.1 mm from the cylinder's circumference. The parallel side of the trapezoid on the top of the cylinder has a length of 9.4 ± 0.2 mm and its centre lies at a depth of 2.6 ± 0.1 mm from the cylinder's circumference. All surfaces of the disc are smooth.

If the use of discs is specified, add a disc to each tube and operate the apparatus as directed under Procedure. The discs conform to the dimensions shown in Figure 2.9.1-1.

The use of automatic detection employing modified discs is permitted where the use of discs is specified or allowed. Such discs must comply with the requirements of density and dimension given in this chapter.

Procedure. Place 1 dosage unit in each of the 6 tubes of the basket and, if prescribed, add a disc. Operate the apparatus using the specified medium, maintained at $37 \pm 2^\circ\text{C}$, as the immersion fluid. At the end of the specified time, lift the basket from the fluid and observe the dosage units: all of the dosage units have disintegrated completely. If 1 or 2 dosage units fail to disintegrate, repeat the test on 12 additional dosage units. The requirements of the test are met if not less than 16 of the 18 dosage units tested have disintegrated.

TEST B - LARGE TABLETS AND LARGE CAPSULES

Apparatus. The main part of the apparatus (Figure 2.9.1-2) is a rigid basket-rack assembly supporting 3 cylindrical transparent tubes 77.5 ± 2.5 mm long, $33.0 \text{ mm} \pm 0.5$ mm in internal diameter, and with a wall thickness of 2.5 ± 0.5 mm. Each tube is provided with a cylindrical disc 31.4 ± 0.13 mm in diameter and 15.3 ± 0.15 mm thick, made of transparent plastic with a relative density of 1.18-1.20. Each disc is pierced by 7 holes, each 3.15 ± 0.1 mm in diameter, 1 in the centre and the other 6 spaced equally on a circle of radius 4.2 mm from the centre of the disc. The tubes are held vertically by 2 separate and superimposed rigid plastic plates 97 mm in diameter and 9 mm thick, with 3 holes. The holes are equidistant from the centre of the plate and equally spaced. Attached to the under side of the lower plate is a piece of woven gauze made from stainless steel wire 0.63 ± 0.03 mm in diameter and having mesh apertures of 2.0 ± 0.2 mm. The plates are held rigidly in position and 77.5 mm apart by vertical metal rods at the periphery. A metal rod is also fixed to the centre of the upper plate to enable the assembly to be attached to a mechanical device capable of raising and lowering it smoothly at a constant frequency of between 29 and 32 cycles per minute, through a distance of 55 ± 2 mm.

The assembly is suspended in the specified liquid medium in a suitable vessel, preferably a 1 litre beaker. The volume of the liquid is such that when the assembly is in the highest position the wire mesh is at least 15 mm below the surface of the liquid, and when the assembly is in the lowest position the wire mesh is at least 25 mm above the bottom of the beaker and the upper open ends of the tubes remain above

the surface of the liquid. A suitable device maintains the temperature of the liquid at 35-39 °C.

The design of the basket-rack assembly may be varied provided the specifications for the tubes and wire mesh are maintained.

Method. Test 6 tablets or capsules either by using 2 basket-rack assemblies in parallel or by repeating the procedure. In each of the 3 tubes, place 1 tablet or capsule

and, if prescribed, add a disc; suspend the assembly in the beaker containing the specified liquid. Operate the apparatus for the prescribed period, withdraw the assembly and examine the state of the tablets or capsules. To pass the test, all 6 of the tablets or capsules must have disintegrated.

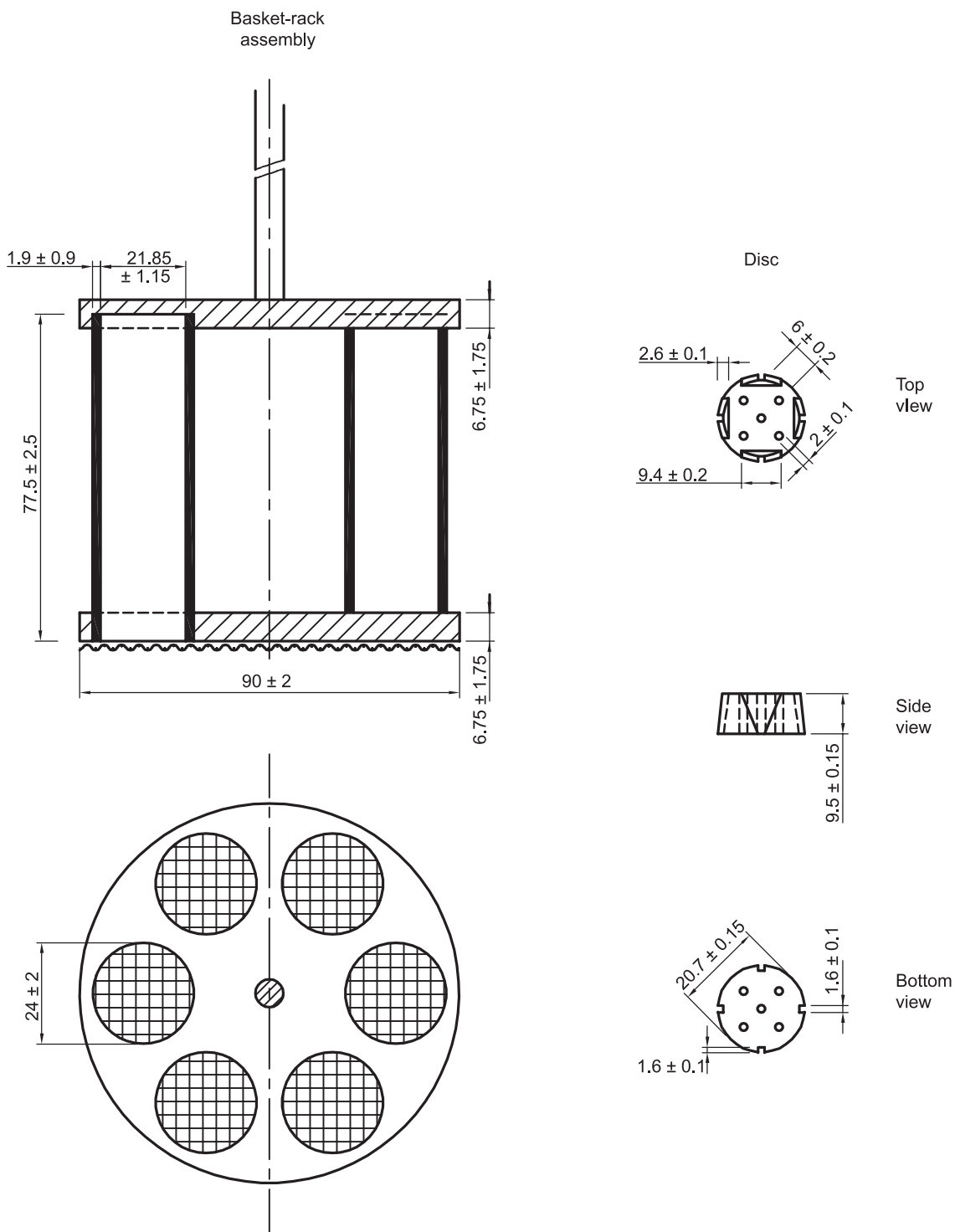

Figure 2.9.1-1. – Disintegration apparatus A
Dimensions in millimetres

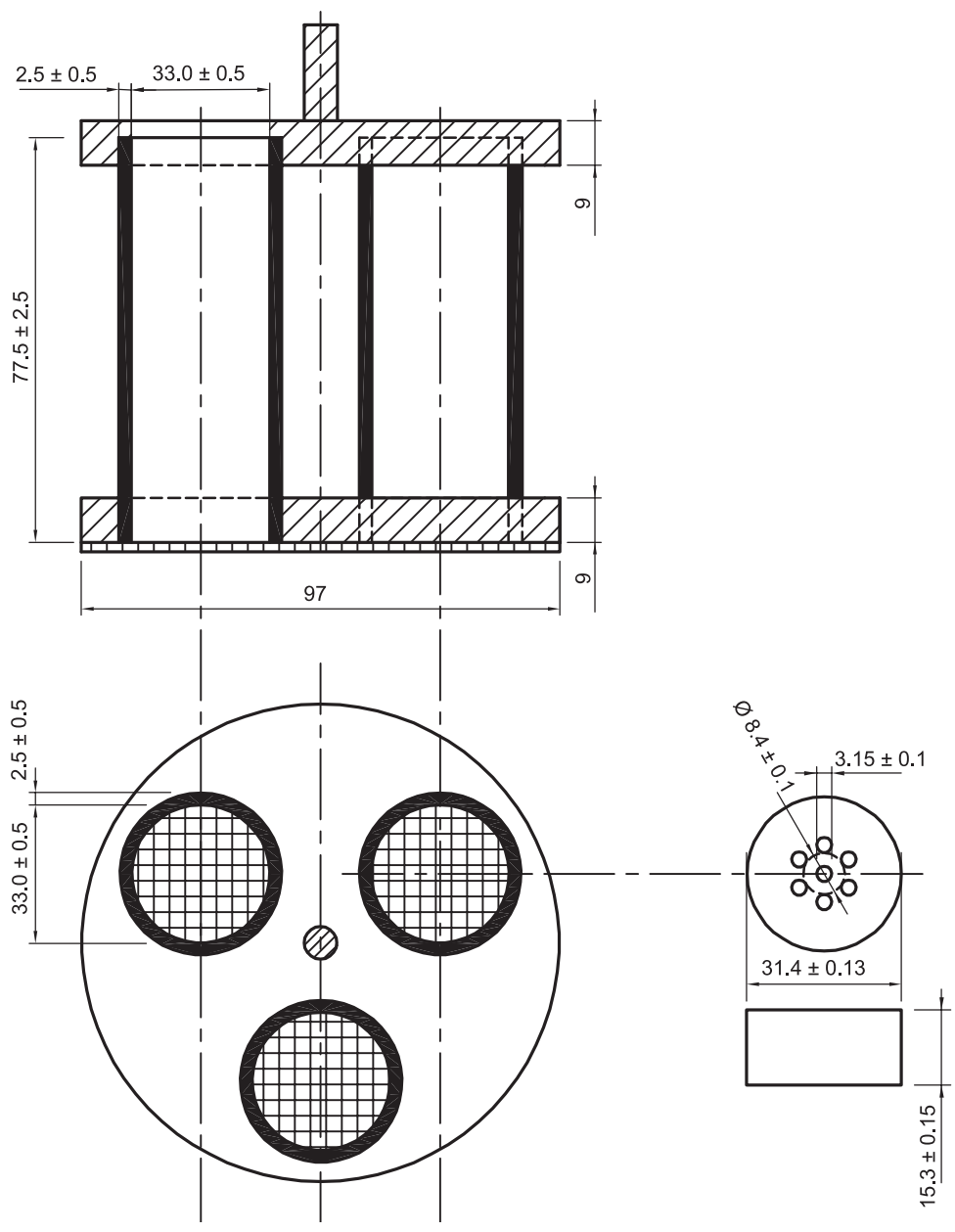

Figure 2.9.1.-2. – Disintegration apparatus B
Dimensions in millimetres

2.9.2. DISINTEGRATION OF SUPPOSITORIES AND PESSARIES

The disintegration test determines whether the suppositories or pessaries soften or disintegrate within the prescribed time when placed in a liquid medium in the experimental conditions described below.

Disintegration is considered to be achieved when:

- a) dissolution is complete,
- b) the components of the suppository or pessary have separated: melted fatty substances collect on the surface of the liquid, insoluble powders fall to the bottom and soluble components dissolve, depending on the type of preparation, the components may be distributed in one or more of these ways,

- c) there is softening of the sample that may be accompanied by appreciable change of shape without complete separation of the components, the softening is such that the suppository or pessary no longer has a solid core offering resistance to pressure of a glass rod,
- d) rupture of the gelatin shell of rectal or vaginal capsules occurs allowing release of the contents,
- e) no residue remains on the perforated disc or if a residue remains, it consists only of a soft or frothy mass having no solid core offering resistance to pressure of a glass rod (vaginal tablets).

Apparatus. The apparatus (Figure 2.9.2.-1) consists of a sleeve of glass or suitable transparent plastic, of appropriate thickness, to the interior of which is attached by means of three hooks a metal device consisting of two perforated stainless steel discs each containing 39 holes 4 mm in diameter; the diameter of the discs is similar to that of the interior of the sleeve; the discs are about 30 mm apart. The test is carried out using three such apparatuses each containing a single sample. Each apparatus is placed in a